

# HAWORTH

One Haworth Center  
Holland, Michigan  
49423-9576 USA

phone 616.393.3000  
fax 616.393.1570

haworth.com

November 3, 2016

**Subject:** Office Humidity and Haworth Wood Flooring Planks

For buildings utilizing the Haworth Wood Flooring product it is important to keep the building humidity controlled to a relative humidity between 40% and 60% RH to be covered by the Haworth warranty.

**Why is it important to keep the humidity in this range?**

**High Humidity Levels** - If the humidity level goes above 60% relative humidity, the wood pores are opened up and more moisture can seep into the wood. Too much moisture could cause the floor boards to begin to swell and expand beyond the capacity of the expansion joints and wall gaps. This swelling can create pressure between the boards, which can cause the boards to warp or bow.

**Low Humidity Levels** - If the humidity level drops *below* 40%, low moisture levels can cause the wood to dry out, which, in turn, could cause the floor to shrink. This can lead to undesirable gaps between planks as well as upward cupping at the ends of the planks. It could also lead the floor to "check", meaning that it could split along the grain. This can also damage the finish, which could become an issue during regular maintenance.

**Keeping Humidity Levels in Check** - So how you can prevent potential damage? Check the humidity levels in the rooms where you have your hardwood floors installed using a [humidistat](#) or a hydrometer. If the humidity levels are outside of the 40% - 60% range, then make adjustments. If the levels are too high, use a dehumidifier or turn up the air conditioning. Either will lower the humidity levels. If you need to *raise* the humidity level, try a [humidifier](#) to boost the overall moisture in the space.

By maintaining the humidity levels between 40% and 60%, you will ensure your floor remains covered by our warranties *and* keep it in shape to perform its best.



# HAWORTH WOOD FLOORING SYSTEM

## Engineered Wood Magnetic Floor

### Installation Instructions

#### Tools Required

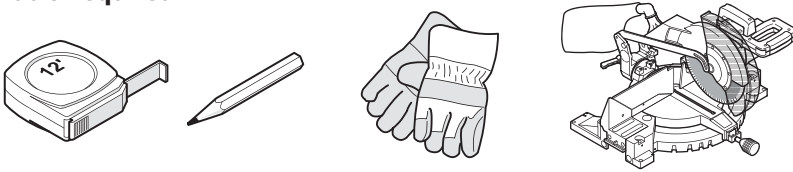

The Haworth Wood Flooring System product is a natural wood product and reacts similarly to standard hard wood flooring. It is important to follow the instructions below to ensure the quality of the product and installation.

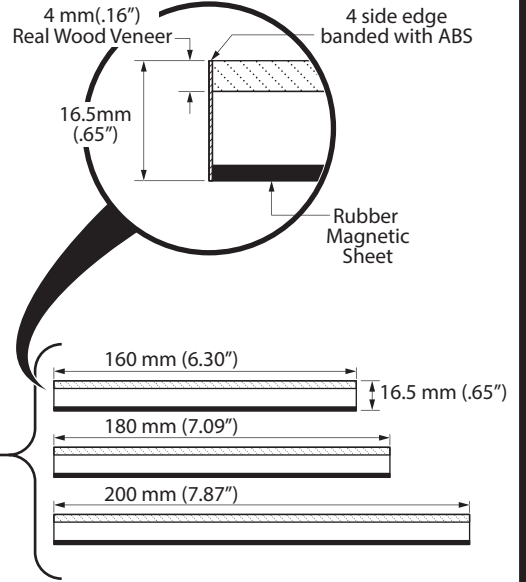
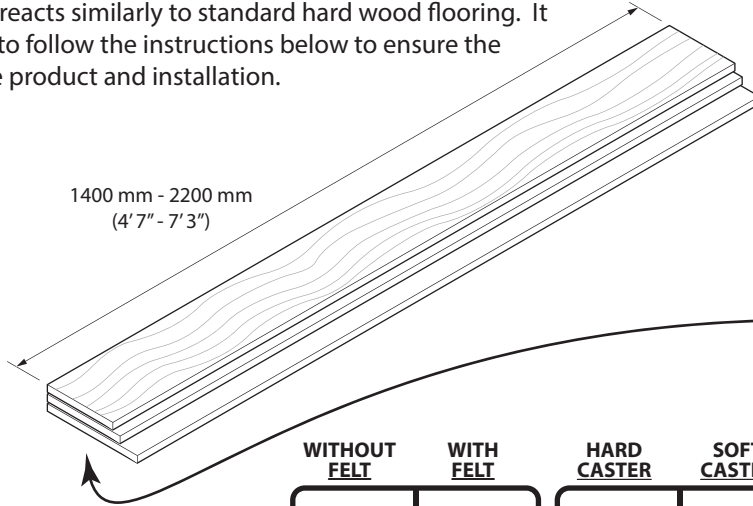

END VIEW

#### PROJECT PLANNING

**1**

- Determine the design and layout of the floor.
  - Determine the methods for wall trimming and floor covering transitions.
  - When planning the layout, it may be easier to try cutting the Access Floor panels width than cutting a panels length.
  - Undercutting around cabinets/walls makes for an easier installation.

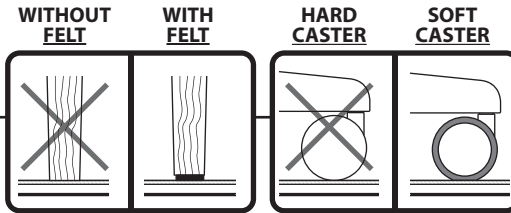

**IMPORTANT:** Use soft wheels and non-marking rubber or felt glides on hard floors to prevent scratches and light spots from abrasion.

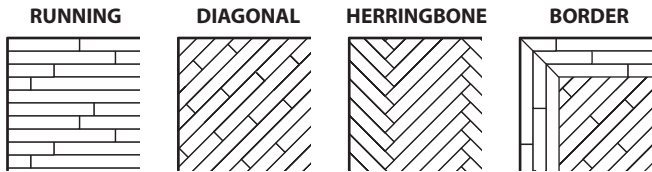
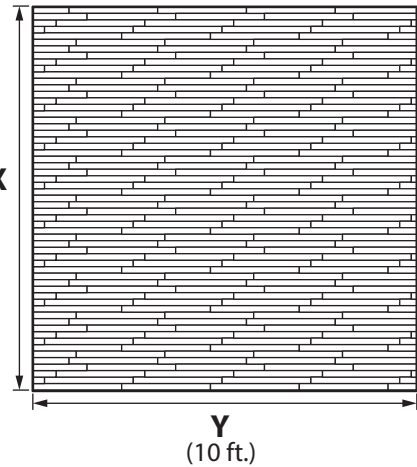

- Cutting allowance of 5% should be ordered in addition to the actual square footage.
  - Cutting allowance will vary depending on layout (diagonal, herringbone and bordered installations require a higher cutting allowance of approx. 12%).

#### Average Installation Rate for "Haworth Wood Flooring System"

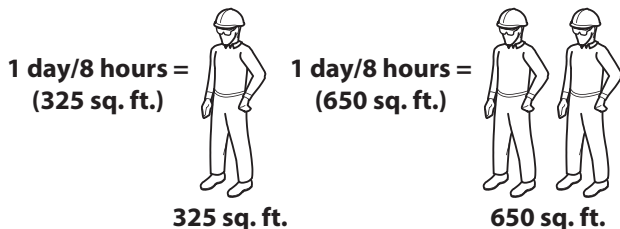

#### X x Y = SQUARE FOOTAGE

**EXAMPLE:**  
10 ft x 10 ft = 100 sq. ft.

**CUTTING ALLOWANCE**  
**SQUARE FOOTAGE + 5% =**

**EXAMPLE:**  
100 sq. ft. x 0.05 = 5 sq. ft.

Plan for transition edge. See Section 6.

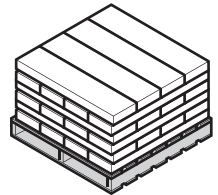

CUSTOMER SERVICE PHONE: 1-800-426-8562

**HAWORTH**

E.C.O. No: 50000008734

Page: 1 of 5

Part No: hawwoodsyst

Rev: A

## PRE-INSTALLATION

2

- 1) Do not store Haworth Wood Flooring System in an unconditioned space. Wood flooring should be kept between 40% and 60% relative humidity with temperatures between 50°F and 80°F.
- 2) Once material is received at the job sites, store Haworth Wood Flooring System on a flat surface (do not bridge the material across two pallets as this can create crowned planks).
- 3) Do not unwrap the Haworth Wood Flooring System until just before installation.
- 4) A flat installation of the Raised Access Floor is critical to a successful Haworth Wood Flooring System installation. The Raised Access Floor surface must be completely clean before the installation of the Haworth Wood Flooring System. If steel top sheet panels will be installed before heavy work is complete cover floor with plywood or RAM board to protect against denting.

**IMPORTANT: Make sure the Steel top sheet panels are level. Panels MUST NOT be dented and/or bent.**

- 5) It is recommended to install Haworth Wood Flooring System at the end of the construction phase, after all the heavy work is completed. It is recommended to complete the following before installing the wood planks:
  - Building is sealed and space is properly conditioned
  - Complete installation of ceiling, lighting, walls, and electric and hydraulic lines
- 6) After wood is installed put down plastic then ram board on top to help prevent discoloration or damage to the wood.

## EXPANSION JOINTS

4

An expansion joint is installed every 50 ft on the width of the planks and every 100 ft on the length of the planks.

### Edges:

**NOTE:** Around the perimeter of the floor leave a 1/4" space. This is covered by the wall base.

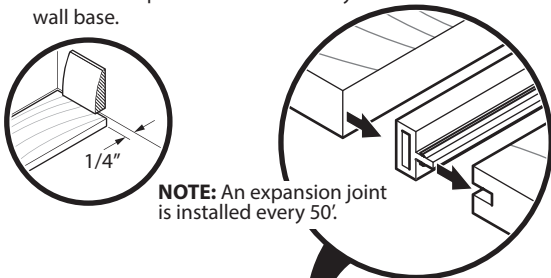

**NOTE:** An expansion joint is installed every 50'.

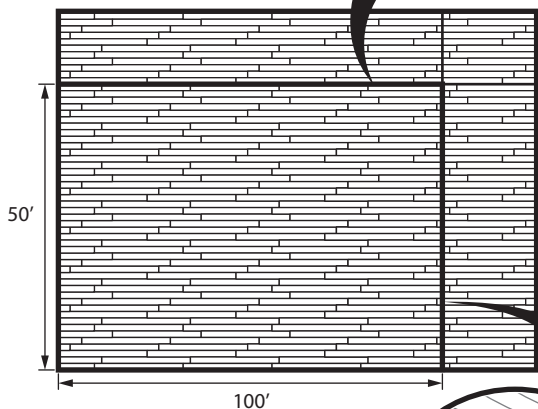

Router to put grooves into planks for expansion joints:

- DeWalt 1-1/4" HP Torque
- Router Bit: 5/32"
- Minimum Depth: 10mm
- Variable Speed
- Compact Router or Equivalent

**NOTE:** An expansion joint is installed every 100'.

## INSTALLATION TOLERANCES

3

**WIDTH**

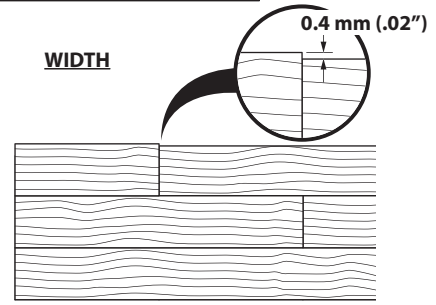

**HEIGHT**

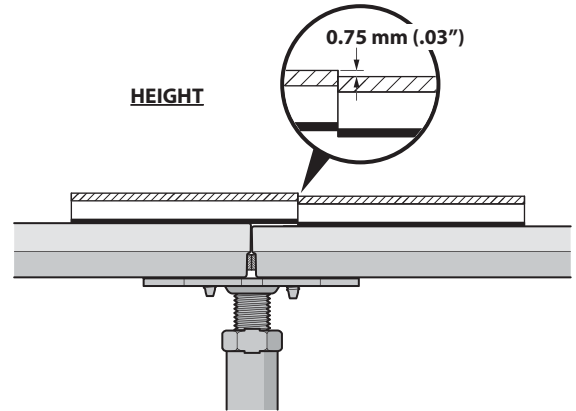

## END CUTS

5

Never waste materials. The end cuts from starter rows should be used at the opposite side of the room to complete rows or used to start the next row.

- When cutting planks, place the cut edge against the wall to keep the beveled edge at the visible seams.
- Cut planks should be longer than 12" to maximize adhesion between the magnet and steel panel and ensure a flat floor.

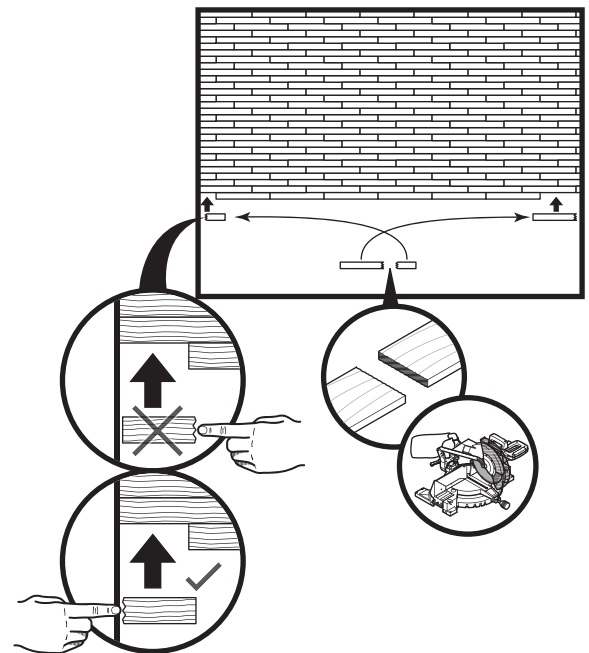

**END CUTS**

CUSTOMER SERVICE PHONE: 1-800-426-8562

**HAWORTH**

E.C.O. No: 50000008734

Page: 2 of 5

Part No: hawwoodsyst

Rev: A

## INSTALLATION INSTRUCTIONS

6

- 1) "Racking the Floor" is essential to achieve a random appearance.
  - Start by either using random-length planks or by cutting four or five planks in random lengths, differing by at least six inches.
  - As you continue working across the floor, try to maintain a six inch minimum distance between end joints. Randomly install different lengths to avoid a patterned appearance.
  - Due to the color lot variation in natural wood products, best practice is to install planks at random from different shipping packages to achieve the most aesthetically pleasing appearance.
- 2) Installing Planks
  - Make sure access floor and wood plank magnet are both free of debris, dust clean and mop the access floor.
  - Visually inspect the wood surface to make sure it's free of surface defects. If there is a surface defect, use plank for perimeter cuts.
  - Lay planks in place and push together to tighten joints. Inspect each plank for magnetic adhesion (no bounce in plank). If the plank is not adhering to the access floor due to excess warp, allow the product to acclimate on a flat surface for 24-48 hours. If still not adhering after acclimation time, see field remedy instructions below.
  - Depending on the size of the installation, a 1/4" space around the perimeter is recommended to allow for expansion.
  - Short perimeter pieces are most susceptible to humidity changes. Best to cut no shorter than 12" lengths if possible. Carpet tape may be necessary to keep short pieces in place.
- 3) Installation Transition Edge
  - Transition strips are specified by the architect. There are many options. Some possible sources can be found at the following websites.
    - <http://www.genotek.com/>
    - [http://www.schluter.com/schluter-us/en\\_US/Profiles/For-Floors/c/P-FF](http://www.schluter.com/schluter-us/en_US/Profiles/For-Floors/c/P-FF)
    - <http://www.johnsonite.com/WallBase,FinishesAccessories/FinishingAccessories.aspx#subfloor>
- 4) Criteria for installation
  - Relative humidity of the project site must be maintained between a minimum 40% and a maximum 60%.
- 5) For plank removal
  - The single-cup panel lifter is recommended.
  - Lifter may not work on specialty finishes.

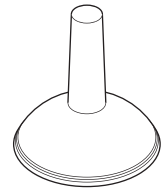

Large Single-Cup Panel Lifter  
Part # 7035-4011

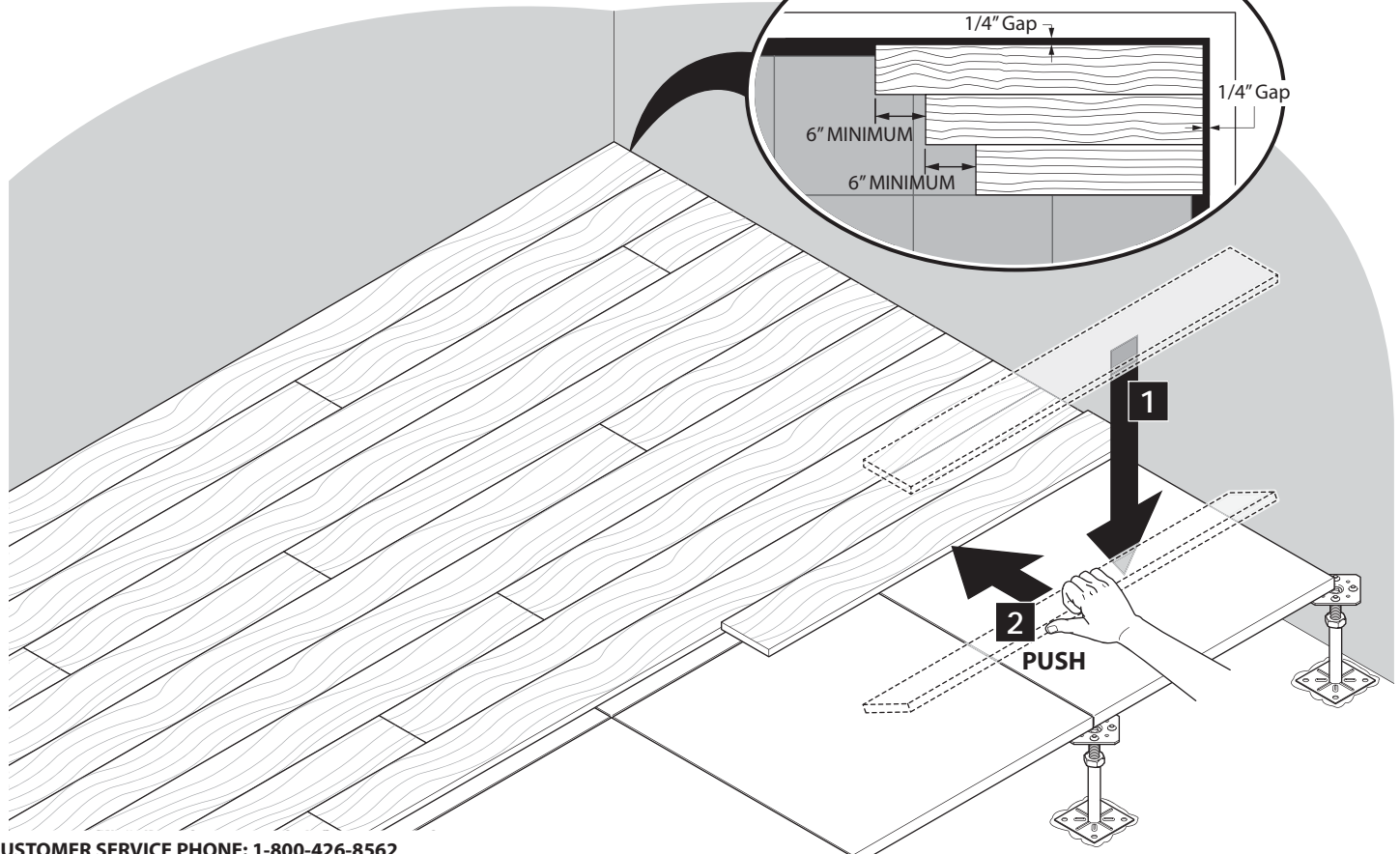
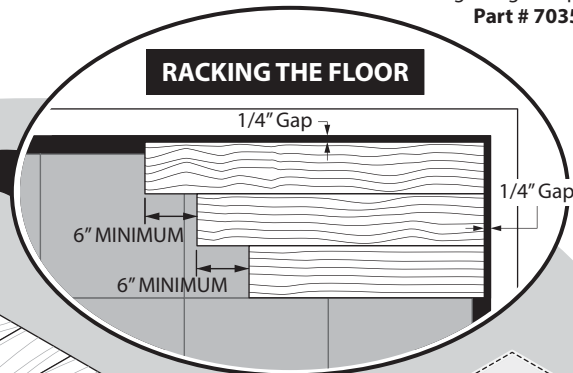

CUSTOMER SERVICE PHONE: 1-800-426-8562

**HAWORTH**

E.C.O. No: 50000008734

Page: 3 of 5

Part No: hawwoodsyst

Rev: A

## FIELD REMEDY

**7** The Haworth Wood Flooring System product is a natural wood product which means it is sensitive to humidity changes. While installing the Haworth Wood Flooring System wood planks, it is possible for the wood planks to have a slight crown which would prevent the magnet from adhering to the Raised Access Floor panel. We recommend the following steps during installation to remedy a Haworth Wood Flooring System plank.

- 1) Check to make sure the Haworth Steel Top Sheet Access Floor panel surface is flat and free of debris. Replace Haworth Steel Top Sheet Access Floor panels if surface is uneven. If cornerlocked, ensure the cornerlock screw is sitting flush with panel. If a stringer system, ensure the each panel is sitting flush on the stringer. Check to make sure the Haworth Steel Top Sheet Access Floor system is leveled properly.
- 2) Use double sided carpet tape to hold wood to the floor if there are short pieces or edge areas that are not holding tightly to the floor.

CUSTOMER SERVICE PHONE: 1-800-426-8562

**HAWORTH**<sup>®</sup>

E.C.O. No: 50000008734

Page: 4 of 5

Part No: hawwoodsyst

Rev: A

**HAWORTH WOOD FLOORING SYSTEM  
Engineered Wood Magnetic Floor**

**Initial Maintenance**

- Remove adhesive residue or petroleum based products with full strength OSMO Wash & Care. Removal should be immediate as it becomes extremely difficult to remove when cured.
- Floor should be swept, dust mopped or vacuumed immediately following installation to prevent scratching of the floor.
- Before turning space over to customer do the initial cleaning with OSMO Wash & Care.
- For buildings utilizing the Haworth Wood Flooring product it is important to keep the building humidity controlled to a relative humidity between 40% and 60% RH to be covered by the Haworth warranty.

**Ongoing Maintenance**

- If wood is at an entry way walk off mats are recommended to protected floor from dirt & elements.
- Use protective casters, non-marking rubber or felt glides on furniture, chairs, tables, etc. This will help to prevent scratching, scuffing or other damage.
- Immediately clean any spills from the floor. Floors become slippery when wet.
- Rolling heavy carts over the wood after installation is not recommended. If required the wood should be protected with 1/8" RAM board.
- Weekly use vacuum cleaner with soft wheels or green dust mop to clean the surface.
- Weekly Damp mop floor with Osmo Wash and Care. The soap contain some soap + wax + oil, therefore the more you wash the floor the better it will look over time.
- Monthly apply Maintenance and protective surface renewal using Osmo Polyx®-Oil.

**Quick Fix Tips**

- Spots/Rubber Heel Marks
  - Apply hardwood floor cleaner to a clean, soft cloth and rub area to remove stain or spot.
  - Use OSMO Wash & Care full strength.
- Gum/Wax
  - Apply sealed plastic bag with ice over spot. Gum or wax will become brittle and crumble off.
  - After removal of excess gum/wax clean hardwood with floor cleaner such as OSMO Wash & Care using a clean, soft cloth.
- Minor Abrasions/Scratches
  - Use "MINWAX" stain markers to touch-up minor abrasions or scratches.
- Deep Scratches/Gouges
  - Use Polyx oil to make the scratch blend into floor.
  - Major damage will require plank replacement.
- Direct Sunlight Protection

**NOTE:** For minor abrasions or scratches use "MINWAX" stain markers that matches the color of the wood.

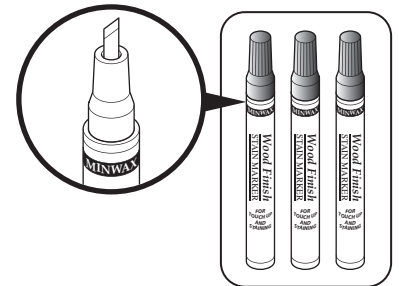

**Refresh/Intensive Cleaning**

- Heavily soiled surfaces should be cleaned using "OSMO Liquid Wax Cleaner" with small amounts applied directly to the affected areas.

Class	Use Level	Description	Care
1	Light	seldom used meeting rooms, storage and technical facilities	<ul style="list-style-type: none"> <li>• Weekly manual maintenance with Osmo Wash &amp; Care</li> <li>• Annual Osmo Oil</li> </ul>
2	Occasional	meeting rooms	<ul style="list-style-type: none"> <li>• 2-3x/wk Osmo Wash &amp; Care</li> <li>• Quarterly Osmo Maintenance Oil</li> </ul>
3	Daily	offices, public spaces, hallways and transitional areas	<ul style="list-style-type: none"> <li>• 2-3x/wk Osmo Wash &amp; Care</li> <li>• Quarterly Osmo Maint. Oil</li> <li>• Annual renovation 1</li> </ul>
4	Intensive	cafeterias, areas in front of lifts and entrance areas	<ul style="list-style-type: none"> <li>• Daily Osmo Wash &amp; Care</li> <li>• Monthly Osmo Maint. Oil</li> <li>• Annual - Bi-annual renovation</li> </ul>

**Protective Surface Renewal**

- To retain original surface properties, worn areas must be renewed after cleaning the floor surface, allow floor to dry thoroughly and apply a thin coat of Polyx oil. ([http://www.osmona.com/pdfs/install/osmo\\_polyx\\_application\\_instructions.pdf](http://www.osmona.com/pdfs/install/osmo_polyx_application_instructions.pdf))

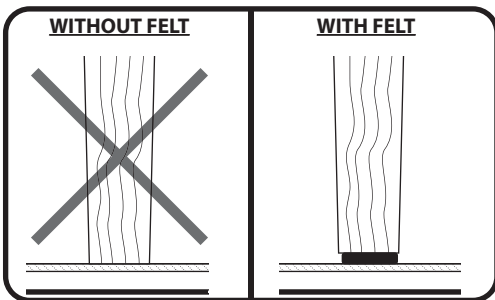

**IMPORTANT:** Use non-marking rubber or felt glides on hard floors to prevent scratches and light spots from abrasion.

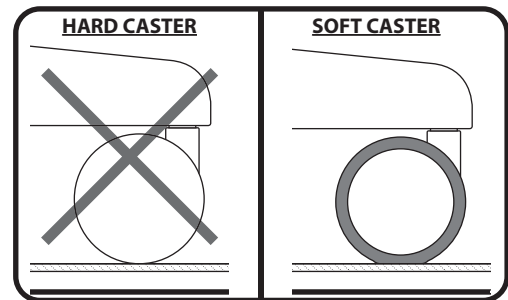

**IMPORTANT:** Use soft wheels for hard floors! **DO NOT** use hard wheels or scratches and light spots from abrasion will appear within a few weeks.

CUSTOMER SERVICE PHONE: 1-800-426-8562

This North American Haworth Floor Product Limited Warranty Policy (“Policy”) applies to floor products manufactured on or after May 1, 2016. For floor products manufactured before that date, please refer to the applicable Haworth warranty policy published in the North American Haworth Price List when the product was purchased or leased or contact your local authorized Haworth dealer.

If a new floor product identified in the table below (each, a “Covered Product”) that is purchased or leased from Haworth, Inc. or Haworth, Ltd. (each called “Haworth”), or from an authorized Haworth Flooring Contractor, is determined by Haworth to be defective (as defined in this Policy) at the time of such purchase or lease, and if the initial purchaser or lessee, within the Applicable Warranty Period, sends notice of the defect to Haworth, Inc. then, upon notice from Haworth, except as provided below, Haworth will, at Haworth’s option, either repair or replace the Covered Product, at Haworth’s expense, or refund the purchase price or cumulative lease payments, as applicable, of the Covered Product to the initial purchaser or lessee.

Except as provided below, a Covered Product is considered “defective” for purposes of this Policy if Haworth determines that (a) the Covered Product is defective in material or workmanship, and (b) solely as a result of such defect, the Covered Product fails to meet in any material respect any warranted performance for the Covered Product that is described below and (c) the defect materially impairs the value of the Covered Product to the initial purchaser or lessee. Each Covered Product’s Applicable Warranty Period begins on the Covered Product’s date of manufacture. Any replacement components supplied by Haworth in connection with the repair or replacement of a Covered Product that is made pursuant to this Policy are warranted for the balance of the Covered Product’s Applicable Warranty Period.

A defect in material or workmanship excludes, and Haworth will not have any responsibility or liability for, any defect or failure consisting of, or caused in whole or in part by, any of the following: (a) normal wear and tear; (b) an Act of God or transportation; (c) a product alteration made without following Haworth’s Application Guideline, Application Drawings or Price List; (d) a failure of the color of a Covered Product or field-applied material to match or be colorfast with another product or material; (e) the application, inconsistency or performance of a field-applied material; (f) delamination of surfaces that were field-applied; (g) variations in color or change in conformity of the natural coloration due to exposure to light sources; (h) the natural variation of color, grain or texture found in wood and other natural materials; (i) misuse or abuse of or damage to the Covered Product; (j) staining; (k) worn or narrow-heeled shoes; (l) furniture or equipment movement or heavy items; or (m) moisture.

The following table shows the Applicable Warranty Period for each Covered Product:

<u>COVERED PRODUCTS</u>	<u>APPLICABLE WARRANTY PERIOD</u>
TecCrete®, floor panels, stringers, pedestal bases and heads . . . . .	Five Years
Airflow floor panels, Accessories and Power Base™ AI . . . . .	Three Years
Haworth-applied High Pressure Laminates (HPL) and the Steel Top Sheet Panel are warranted against delamination from the base panel for . . . . .	Three Years
Haworth Wood Flooring System . . . . .	Two Years
TecBase® and TecCrete® floor panels with all other Haworth-applied surfaces are warranted against delamination from the base panel for . . . . .	One Year

Any floor product that is modified under Haworth’s “Specials” program will have a warranty period that is the same as the standard catalog product that is modified; however, any material modification of the standard catalog product, and any modification of the product’s features, construction, function or aesthetics, will have a 1-year warranty period.

The warranty provided by this Policy does not apply to any product that either (a) is not installed by a Haworth Flooring Contractor or HFC-approved installer; (b) is “Customer’s Own Material” (i.e. material specified by the initial purchaser or lessee that is not a standard Haworth product offering); (c) is not installed and used as recommended in Haworth’s written Application Guideline, Installation Instructions and Maintenance Guides; or (d) is not located at all times in a building that is both (1) dry, fully closed-in and protected from the natural elements, and (2) adequately heated, ventilated and air conditioned in order to maintain an internal temperature:

- Wood System                      constant level between 50°F to 80°F (10°C and 27°C) and relative humidity levels between 40% and 60%
- All Other                            constant level between 40°F to 120°F (4°C and 49°C) and relative humidity levels between 35% and 70%

As a condition to any remedy under this Policy, the initial purchaser or lessee of the applicable Covered Product must comply with all directions and instructions provided by Haworth, a Haworth Flooring Contractor or their respective agents regarding (a) inspection, preservation or safeguarding of the Covered Product and (b) transportation and delivery of the Covered Product to Haworth, an authorized Haworth dealer or other party.



The warranty provided by this Policy extends only to the initial purchaser or lessee of the Covered Product and will automatically terminate at the time that the initial purchaser or lessee ceases to own or lease, respectively, the Covered Product or ceases to solely possess, control and use the Covered Product.

EXCEPT AS STATED ABOVE, HAWORTH DOES NOT MAKE, AND EXPRESSLY DISCLAIMS, ANY WARRANTY AS TO ANY COVERED PRODUCT AND, IN PARTICULAR, DOES NOT MAKE ANY WARRANTY OF MERCHANTABILITY OR OF FITNESS FOR A PARTICULAR PURPOSE. Product repair or replacement or refund of the purchase price or cumulative lease payments, at Haworth's option, in accordance with this Policy, is the initial purchaser's or lessee's exclusive remedy for a product defect. In no event will Haworth have tort liability with respect to a Covered Product or any other product or be liable for any consequential, economic, indirect, special, punitive or incidental damages arising from a product defect.

All determinations regarding the scope, applicability and interpretation of this Policy, including without limitation the satisfaction of and compliance with all conditions and requirements of the warranty set forth in this Policy, shall be made solely by Haworth in its discretion, and all such determinations made by Haworth shall be final, non-appealable and binding on each purchaser and lessee of a Covered Product and their successors and permitted assigns.

For warranty information concerning North American Haworth non-floor products, see the latest applicable published Haworth warranty policy by going to <http://www.haworth.com/bottom-nav/product-info/warranty-info>.